

CONTINUAL MEASUREMENT OF ELECTROMAGNETIC AND ACOUSTIC EMISSION SIGNALS FOR VARIOUS LOADING CONDITIONS.

Tomáš Trčka

Doctoral Degree Programme (3), FEEC BUT

E-mail: xtrcka03@stud.feec.vutbr.cz

Supervised by: Pavel Koktavý

E-mail: koktav@feec.vutbr.cz

Abstract: Stochastic electromagnetic and acoustic emission may be observed when the solid dielectric materials are mechanically stressed. They carry information about micro-cracks generated in tested materials. This paper describes our new set-up, which significantly improves the previous set-up in the several ways, and includes the first experimental results. The new measurement system offers continual measurement of both signals for various loading conditions and their real-time processing and evaluation.

Keywords: crack, electromagnetic emission, acoustic emission, composite material, diagnostics

1. INTRODUCTION

Application of mechanical stress leads to micro-cracks formation in stressed solid dielectric materials.

The cracks generation in the solids is accompanied by the redistribution of the electric charge. The crack walls are electrically charged and their vibrations produce time variable dipole moments. Hence the individual cracks become electromagnetic field sources, which can be measured by appropriate sensors. This phenomenon is called electromagnetic emission (EME) and it may be caused by numerous reasons, such as external pressure, tensile force, shearing, shocks, etc [1].

Acoustic emission (AE) is generated simultaneously with the EME. There is a time delay between arrival times of detected AE and EME signals, which is caused by different propagation velocities of these two phenomena in a sample under examination. The AE signal time latency to the EME signal arrival provides information about the distance of the crack from the AE sensor. Thus, the crack position in the stressed material can be evaluated in a case of the multi-channel AE measurement [2].

The main advantage of EME and AE is their ability to be detected already in stressed stage, which may prevents the macroscopic dislocation in solids. Suitably designed methodology of EME and AE signals measurement, processing and evaluation allows observing the response of stressed materials on applied mechanical load continuously, and also allows to obtain the useful information about the processes taking place in the cracks formation in solids.

2. MEASUREMENT SYSTEM

The main disadvantage of the previous experimental set-up [3] was a manual hydraulic press for the measured samples mechanical loading. This type of press does not allow a computer-controlled regulation of the mechanical load and moreover there is no guaranteed time stability of the set load. Considering these difficulties, a new fully automated measurement set-up for EME and AE evaluation (Fig. 1) was developed in the UFYZ FAST laboratory. The main part of the

measurement system is the adjustable hydraulic press which provides mechanical load of a sample in the range from 10 kN up to 100 kN. The press is controlled by computer via voltage that is set by card NI PCI-6014. Further, this card acquires the output voltage of wheatstone bridge with a sensitive load cell which measures the mechanical load. A deformation meter is used to measure a sample contraction during compressive stress application. A change of the sample length is stored from the meter to computer by the RS-232 port.

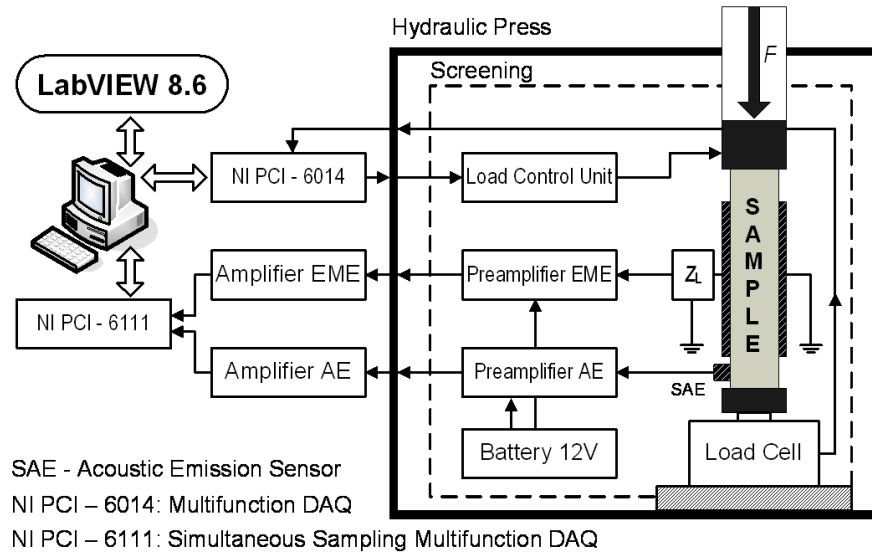

Figure 1: Experimental set-up

The EME channel consists of a capacitance sensor which dielectric is composed of the stressed sample, a high pass-filter-type load impedance Z_L , a low-noise preamplifier PA31, and an amplifier AM22 with a set of filters. The total EME channel gain is 60 dB, the frequency range is from 30 kHz to 1.2 MHz and the sampling rate is of 5 MHz.

The AE channel consists of a piezoelectric acoustic sensor (30 kHz ~ 1 MHz), the low-noise preamplifier PA31 and the amplifier AM22 with a set of filters. The total AE channel gain is 40 dB, the frequency range is from 30 kHz to 1.2 MHz.

The capacitance sensor is commonly used to EME capture. In our case, the capacitance sensor is formed by the specially made adjustable bracket with two electrodes, into which we can easily insert the rectangular samples from studied material.

The piezoelectric sensors from different vendors are used for AE monitoring. These sensors meet the requirements of the AE frequency band (at least up to 1 MHz) and are usually mounted by beeswax to a sample. This attachment provides good mechanical coupling between sample and sensor as well as easy mounting and removing of sensors.

EME and AE signals processing

Both signals of EME and AE are acquired by NI PCI 6111 card and stored to the PC, where further processing is carried out. Whole measurement system is controlled by the PC with software developed under the LabVIEW environment. The complex software package allows finding the typical events in the particular data channels, saving these events as separate files and describing their fundamental parameters. Evaluation process of these parameters and measurement process are provided simultaneously (in real time).

The proposed parameters of AE event were inspired by the technical standard for acoustic emission (ČSN EN 1330-9). The following parameters are detected for the AE signals with a zero mean value for our purposes: Peak amplitude, Start time, Stop time, Event duration, Rise Time, Count (of passing through the zero value), Count to Peak, Average Frequency, Event RMS, Event Energy and

Event Dominant Frequency. The situation is more complicated in case of EME signals. It is necessary to define the appropriate parameters with regard to the considerable variability of these random signals. In the current version of the measurement program following parameters are evaluated: Maximum Amplitude, Start Time, Stop Time, Event Duration, Event RMS, Event Energy and Event Dominant Frequency. The parameter evaluated from both AE and EME signals is Time Delay (between EME and AE signals), which can be calculated easily from the EME and AE events beginnings (EME and AE Start Time parameters). Thus, crack location in material under test may be calculated from this parameter in a case of multi-channel AE measurement. The Crack Distance (from the AE sensor) parameter can be evaluated from the found Time Delay and the acoustic signal propagation velocity in the studied material. Detailed information about the proposed parameters are in [4].

3. EXPERIMENTAL RESULTS

The measured specimen (V4) was prepared from EXTREN 500 composite material based structural profiles. This material is a combination of a fibre glass reinforcement and a resin binder. The binder protects the reinforcement from mechanical damage, maintains the structural profile shape and transfers the tension into the reinforcement. The applied mechanical stress was perpendicular to the reinforcing glass fibre direction [1]. The measured specimen was block of overall dimensions $9.4 \text{ mm} \times 51.0 \text{ mm} \times 71.5 \text{ mm}$.

Linearly increasing uniaxial compression up to the load of 67 kN was applied on the sample V4 with a rate of 25 N/s. The curve of applied force versus sample deformation (contraction) is in Fig. 2. The point 1 indicates the conditions where AE events started their activity. It should correspond to beginning of micro-cracks creation in studied material. The point 2 marks the beginning of EME events. While both signals contain only separated EME and AE events (Fig. 3) for the load below the point 3, the formation of the continuous EME and AE signals appears above it, see Fig. 5. The plastic deformation starts at the last part of the curve and the sample complete destruction follows it.

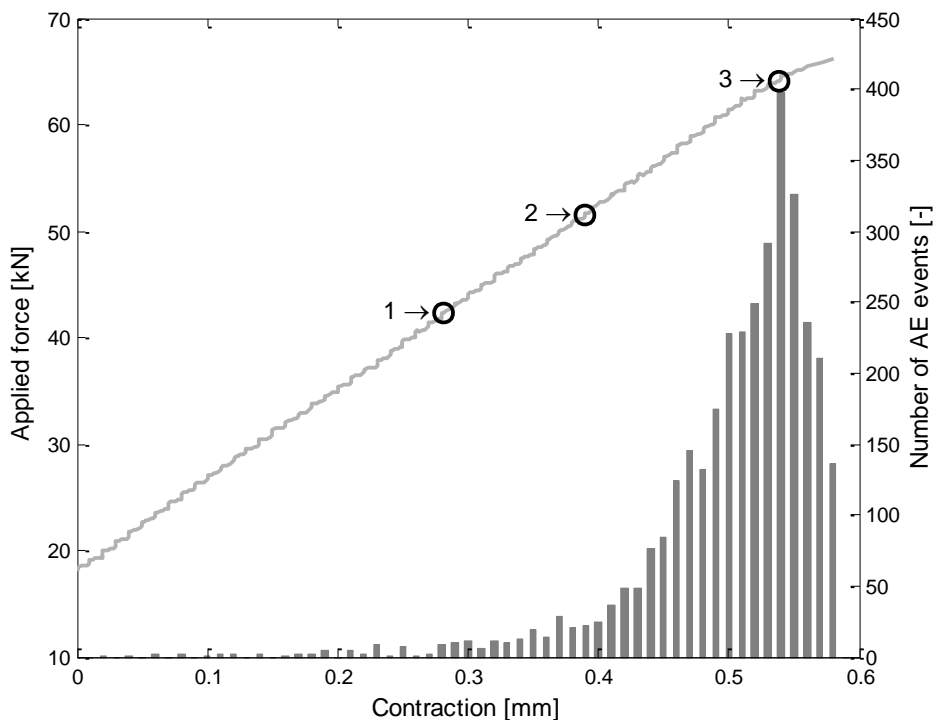

Figure 2: Applied force versus sample contraction

The histogram describing the distribution of the fracture events in time is shown in Fig. 4. Each bar in this chart describes number of AE events during the time interval of 20 s. Number of events in individual time intervals increases, which is in accordance with the fact that the load increases in time. The peak with the maximum value corresponds to the start of the whole sample fracture. Figure 6 illustrates dependence of one fundamental parameter of AE signals (Average Peak Amplitude) in the time interval of 20 s, in time. It is clear that this parameter increases in time with the load increasing.

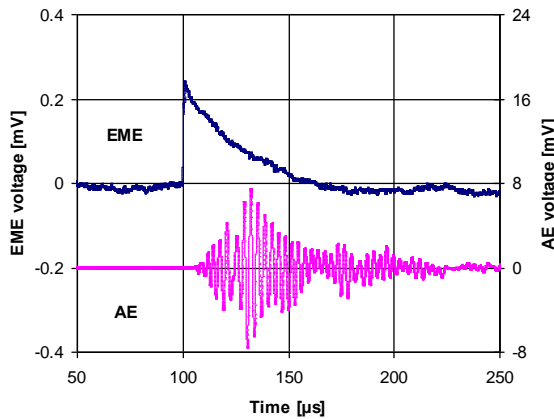

Figure 3: Separated EME and AE events, mechanical load 35,5 kN, sample V4

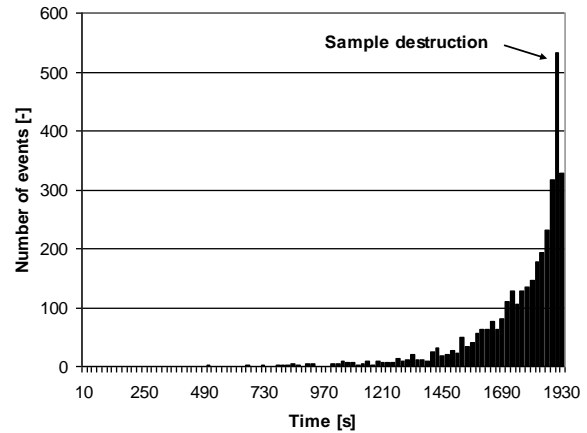

Figure 4: Histogram of fracture events distribution, sample V4, time interval 20 s

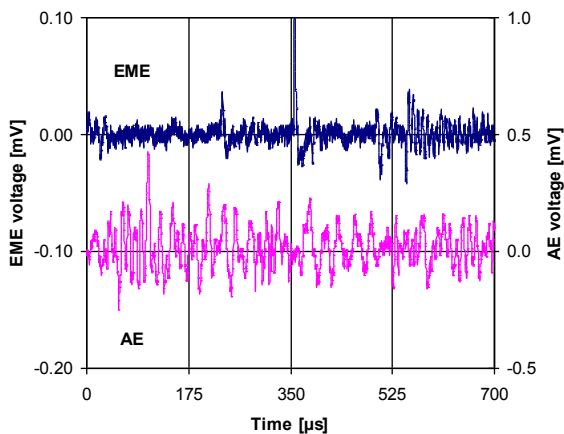

Figure 5: Continuous EME and AE signals, mechanical load 65,4 kN, sample V4

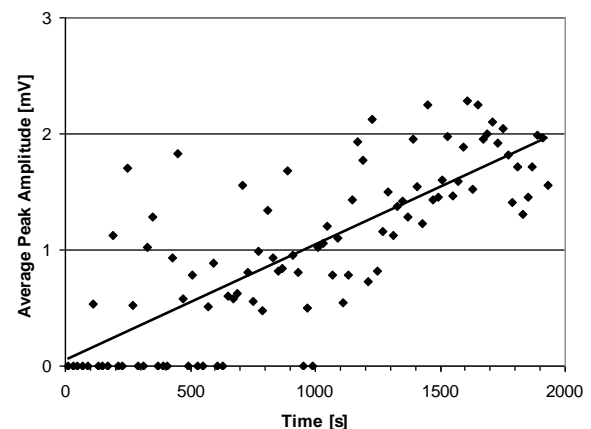

Figure 6: Average Peak Amplitude versus time, sample V4, time interval 20 s

4. CONCLUSION

A new improved set-up was developed for continual EME and AE measurement as well as real-time processing and evaluation. This system is based on the adjustable hydraulic press which provides the specimen mechanical load in the range of 10 kN to 100 kN. The press is electrically controlled by computer and it offers the continual measurement of both signals for various loading conditions. Further improvement is the deformation meter which is used for the sample contraction measuring during compressive stress application. This makes it possible to observe the curve of mechanical load versus sample deformation (contraction) during the sample mechanical loading.

The complex software package was developed in the LabVIEW environment. It allows finding the typical AE events in the individual data channels, saving these events as separate files and describing their basic parameters (event start/end time, maximal amplitude, RMS value, energy, etc.). Processing and evaluation of these parameters is taking place simultaneously (in real-time) with the process of measurement. It offers the possibility to observe the stressed materials response to applied mechanical load in real-time.

The practical application of aforementioned effects may be utilized for the diagnostics of the dielectric solid materials under mechanical stress and particularly for study of the material cracks formation, evolution and localization.

ACKNOWLEDGEMENTS

This research has been supported by the Brno BUT Specific Research, by the Grant Agency of the Czech Republic within the framework of the project GACR 102/09/H074 and by the Czech Ministry of Education in the frame of MSM 0021630503 Research Intention MIKROSYN "New Trends in Microelectronic System and Nanotechnologies". This support is gratefully acknowledged.

REFERENCES

- [1] Koktavý, P.: Experimental study of electromagnetic emission signals generated by crack generation in composite materials. *Measurement Science and Technology*. 2008. 20(1). p. 0 - 7. ISSN 0957-0233.
- [2] Sedlak, P., Sikula, J., Lokajicek T., Mori Y.: Acoustic and electromagnetic emission as a tool for crack localization. *Measurement Science and Technology*. 2008. 19(4). p. 0 - 6. ISSN 0957-0233.
- [3] Trčka, T.: Characteristics of the improved set-up for electromagnetic and acoustic emission signals continual measurement. In *Proceedings of the 16th Conference Student EEICT 2010*. Volume 595. Brno, 2010, NOVOPRESS s.r.o. 2010. p. 139 - 143. ISBN 978-80-214-4079-1.
- [4] Trčka, T., Koktavý, P.: Electromagnetic and acoustic emission signals continual measurement and real time processing. *ElectroScope*. 2010. 2010(3). p. 1 - 4. ISSN 1802-4564. <http://www.electroscope.zcu.cz>.